

INNOVATIVE PRODUCTS  
DESIGNED BY RELIABILITY EXPERTS

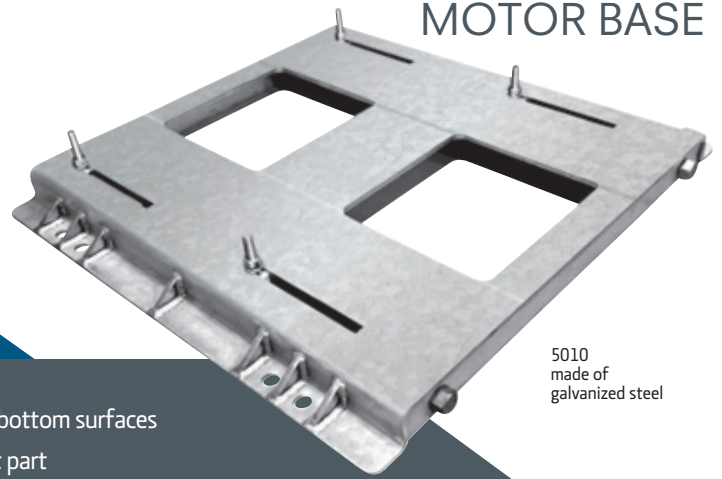

5010  
made of  
galvanized steel

-  Design service
-  Thread protection (optional)
-  Push/pull tensioning system
-  CNC machined top and bottom surfaces
-  Permanent replacement part
-  Material and surface finish options

**Merckell** offers the engineering, drawing and manufacturing of custom double adjusting motor bases of all formats and motor driven assemblies of all kind.

Depending on the available timeframe, its custom motor bases are either bended assemblies or completely

mechanically welded. The upper and lower surfaces are CNC-machined to remove the angular support leg and guarantee a high-quality product.

**Merckell** offers a variety of options: type of steel, coating, color and thread protection.

	D	E	F	G	H	J	M	N	P
Model									

	MANUFACTURING DETAILS		
Material	<input type="checkbox"/> 50W steel	<input type="checkbox"/> Stainless steel	
Finish	<input type="checkbox"/> None	<input type="checkbox"/> Powder coated	<input type="checkbox"/> Galvanized
Threads protection	<input type="checkbox"/> Yes	<input type="checkbox"/> No	
Tensioning screws	<input type="checkbox"/> Zinc	<input type="checkbox"/> Galvanized	<input type="checkbox"/> Stainless steel
Tensioning screws threads	<input type="checkbox"/> Regular	<input type="checkbox"/> ACME 1"-8	
Bolting screws	<input type="checkbox"/> Zinc	<input type="checkbox"/> Galvanized	<input type="checkbox"/> Stainless steel

Fill out the sizing chart for your double adjusting motor base



Made in North America

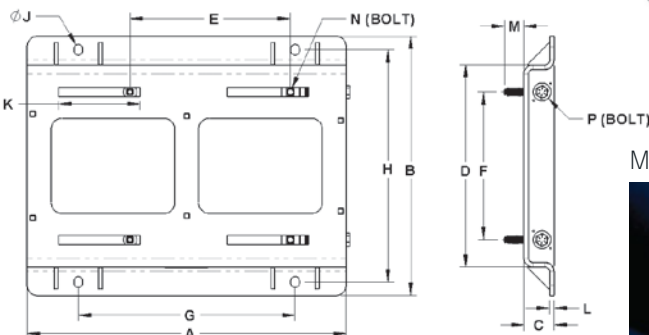

 **HEAD OFFICE**  
70 Maillhot Street  
East Angus, Quebec  
JOB 1R0  
T. : 819-451-0697  
info@merckell.com

 **WORKSHOP**  
1795 Industriel Boulevard  
Door no. 7  
Magog, Quebec  
J1X 5P2

 **REPRESENTATIVE**  
Simon McConnell  
T. : 819-451-2147  
smcconnell@merckell.com

# Industrial Reliability Parts

INNOVATIVE PRODUCTS  
DESIGNED BY RELIABILITY EXPERTS

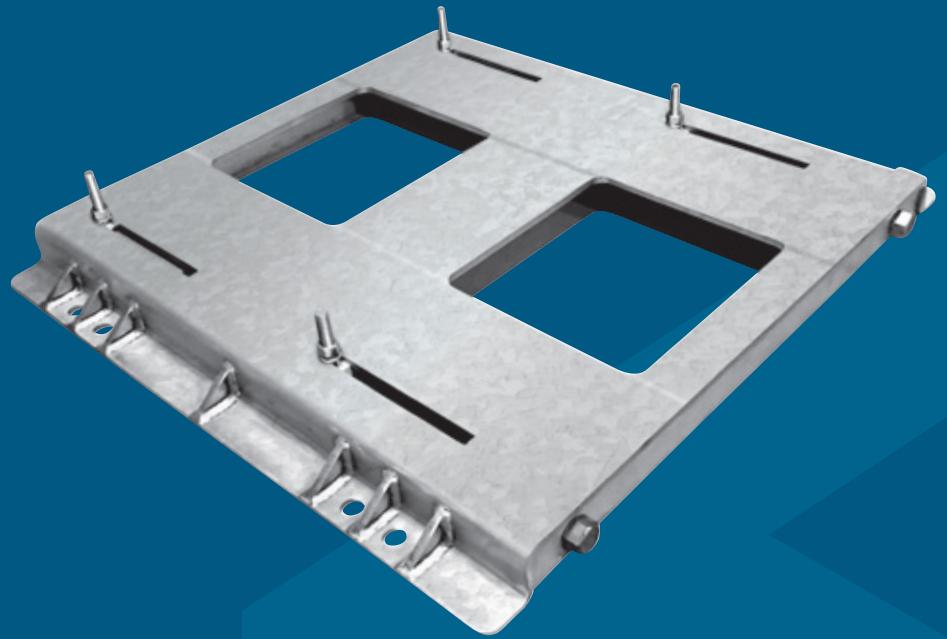

CUSTOM DOUBLE ADJUSTING  
MOTOR BASE

 **HEAD OFFICE**  
70 Maillhot Street  
East Angus, Quebec  
JOB 1R0  
T. : 819-451-0697

 **WORKSHOP**  
1795 Industriel Boulevard  
Door no. 7  
Magog, Quebec  
J1X 5P2

 **REPRESENTATIVE**  
Simon McConnell  
T. : 819-451-2147

 [info@merckell.com](mailto:info@merckell.com)